

Operating instructions

Cryogenic gate valves

9116 / 9116F / 093xx / 094xx

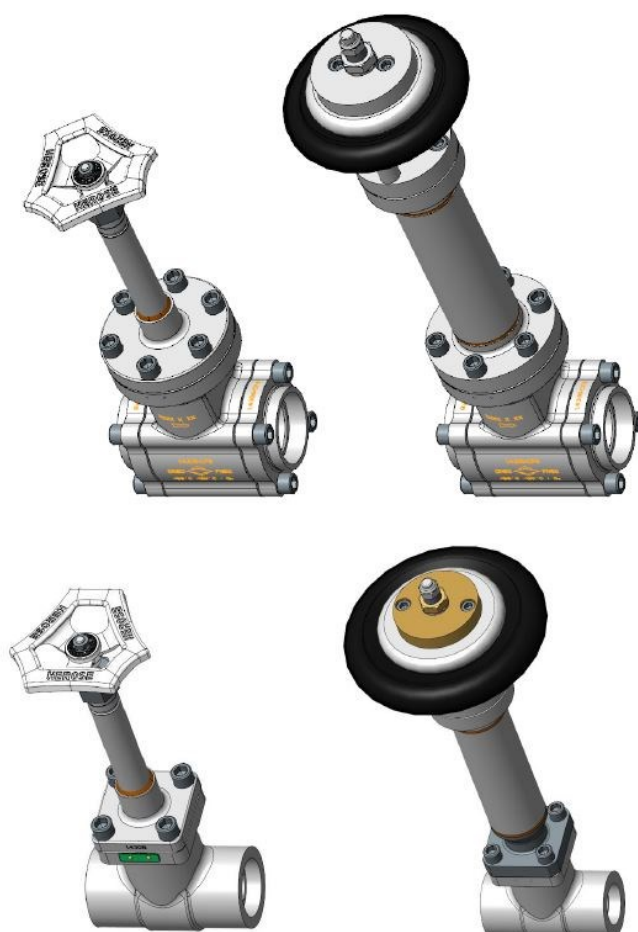

READ CAREFULLY BEFORE USE! RETAIN FOR FUTURE REFERENCE!

© 2018 HEROSE GMBH
ARMATUREN UND METALLE
Elly-Heuss-Knapp-Straße 12
23843 Bad Oldesloe
Germany

Phone: +49 4531 509 – 0
Fax: +49 4531 509 – 120

E-mail: info@herose.com
Web: www.herose.com

1st issue 07/2018

The transmission or duplication of this document and the use or communication of its content are forbidden unless expressly permitted. Any violations shall result in liability for damages. All rights in the event of patent, utility model or registered design are reserved.

Table of contents

1	About these instructions	1
2	Safety	1
3	Transport and storage	4
4	Description of the valve	4
5	Assembly.....	7
6	Operation	10
7	Maintenance and service.....	11
8	Disassembly and disposal	13

1 About these instructions

1.1 Principles

The operating instructions are part of the valve named on the front page.



1.2 Applicable documents

Document	Contents
Catalogue page	Description of the valve

Refer to the manufacturer's documentation for accessories.

1.3 Hazard levels

The warning notes are marked and classified according to the following hazard levels:

Symbol	Explanation
 DANGER	Identifies a hazard with a high risk level that will result in death or serious injury.
 WARNING	Identifies a hazard with a moderate risk level that will result in death or serious injury.
 CAUTION	Identifies a hazard with a low risk level that will result in a minor or moderate injury.
NOTICE	Identifies a risk to property. Damage to property may occur if this note is ignored.

2 Safety

2.1 Intended use

The valve is intended for installation in a pipeline or pressure tank system in order to block media or allow them to pass through within the permissible operating conditions. The permissible operating conditions are specified in these operating instructions.

The valve is suitable for the media listed in these operating instructions; see section 4.5 "Media".

Operating conditions and applications deviating from these require the approval of the manufacturer.

Only media may be employed to which the materials used for the valve body and seals are resistant.

Contaminated media or usage outside of the pressure and temperature specifications can lead to damage to the valve body and seals.

Avoidance of foreseeable incorrect use

- ▶ Never exceed the permissible usage limits specified in the data sheet or in the documentation with regard to pressure, temperature, etc.
- ▶ Follow all safety instructions and operating procedures in these operating instructions.

2.2 Meaning of the operating instructions

The operating instructions are to be read and followed by the responsible technical personnel before installation and start-up. As part of the valve the operating instructions must always be available close to it. People could be seriously injured or killed if the operating instructions are not followed.

- ▶ Read and observe the operating instructions before using the valve.
- ▶ Retain the operating instructions and make sure they are available.
- ▶ Pass on the operating instructions to subsequent users.

2.3 Instructions for people who work with the valve

People could be seriously injured or killed if the valve is used improperly. In order to avoid accidents, all persons who work with the valve must meet the following minimum requirements.

- They are physically capable of controlling the valve.
- They can safely carry out the work with the valve within the scope of these operating instructions.
- They understand the operating principles of the valve within the scope of their work and are able to recognise and avoid the hazards of the work.
- They have understood the operating instructions and are able to implement the information of the operating instructions accordingly.

2.4 Personal protective equipment

Missing or unsuitable personal protective equipment increases the risk of damage to health and injuries to people.

- ▶ The following protective equipment is to be provided and worn during work:
 - Protective clothing
 - Safety shoes
- ▶ Set out and use additional protective equipment depending on the utilisation and the media:
 - Safety gloves
 - Eye protection
 - Ear protection
- ▶ Wear the specified personal protective equipment for all work on the valve.

2.5 Additional equipment and spare parts

Additional equipment and spare parts not conforming to the manufacturer's requirements can negatively affect the operational safety of the valve and cause accidents.

- ▶ In order to ensure operational safety, use original parts or parts that conform to the manufacturer's requirements. If in doubt, have these confirmed by the dealer or manufacturer.

2.6 Adhere to the technical thresholds

If the technical thresholds for the valve are not adhered to, the valve may sustain damage, accidents may be caused and people may be seriously injured or killed.

- ▶ Adhere to the thresholds. See section "4 Description of the valve".

2.7 Safety instructions

DANGER

Hazardous medium.

Escaping operating medium can lead to poisoning, burns and caustic burns!

- ▶ Wear the prescribed protective equipment.
- ▶ Provide suitable collecting containers.

Slipping of the valve out of the suspension.

Danger to life from falling parts!

- ▶ Do not suspend the valve by the handwheel.
- ▶ Note the weight specifications and the centre of gravity.
- ▶ Only use suitable and approved load handling equipment.

WARNING

Harmful and/or hot/cold conveyed media, lubricants and fuels

Hazardous for persons and the environment!

- ▶ Collect and dispose of rinsing medium and any residual media.
- ▶ Wear protective clothing and a protective mask.
- ▶ Observe legal regulations regarding the disposal of harmful media.

CAUTION

Cold/hot pipelines and/or valves.

Risk of injury due to thermal influences!

- ▶ Insulate valves.
- ▶ Attach warning signs.

Medium escaping at high speed and high/low temperature.

Risk of injury!

- ▶ Wear the prescribed protective equipment

NOTICE

Impermissible stresses arising from operating conditions and extensions / added structures.

Leakage or rupture of the valve body!

- ▶ Provide suitable support.
- ▶ Additional loads, such as traffic, wind or earthquakes, are not explicitly taken into account by default and require separate dimensioning.

Condensation in air conditioning, cooling and refrigeration plants.

Icing!

Blocking of the actuation mechanism!

- ▶ Damage due to corrosion!
- ▶ Insulate valves with impermeable material

Improper installation.

Damage to the valve!

- ▶ Remove cover caps before installation.
- ▶ Clean the sealing surfaces.
- ▶ Protect the body against impacts.

Improper handling.

Leaking valve or damage to the valve!

- ▶ Do not store tools and/or other objects on the valve.
- ▶ Do not use tools to increase the torque of the hand wheel.

Painting of valves and pipelines.

Functional impairment of the valve / loss of information!

- ▶ Protect spindle, plastic parts and type plate against the application of paint.

Impermissible stress

Damage to the control mechanism!

- ▶ Do not use the valve as a foothold.

Exceeding the maximum permissible operating conditions.

Damage to the valve!

- ▶ The maximum permissible operating pressure must not be exceeded, and the minimum and maximum permissible operating temperatures must be observed.

Welding beads, scale and other contaminants.

Damage to the valve!

- ▶ Take appropriate measures against contamination.
- ▶ Remove contaminants from the pipes.

Incorrect earthing during welding work in the pipeline.

Damage to the valve (burned spots)!

- ▶ Remove bonnet during welding.
- ▶ When carrying out electric welding work, do not use functional parts of the valves for earthing.

Exceeding the maximum permissible operating temperature.

Damage to the valve!

- ▶ Create the welding/soldering stepwise so that the warming in the middle of the body does not exceed the maximum permissible operating temperature.

3 Transport and storage

3.1 Inspection of condition on delivery

- ▶ Inspect the valve for damage upon receipt.
In case of transport damage, determine and document the precise extent of the damage, and report it immediately to the supplying dealer/carrier and the insurer.

3.2 Transportation

- ▶ Transport the valve in the packaging supplied.
The valve is delivered ready to operate with lateral connections protected by cover caps.
- ▶ Protect the valve against shocks, impacts, vibrations and dirt.
- ▶ Adhere to a transport temperature range of -20 °C to +65 °C.

3.3 Storage

- ▶ Store the valve in a clean and dry place.
- ▶ Make use of a desiccant or heating in damp storerooms to prevent the formation of condensation.
- ▶ Adhere to a storage temperature range of -20 °C to +65 °C.

4 Description of the valve

- ▶ See catalogue page.

4.1 Structure



Design

Non-automatic opening and closing gate valve, with handwheel or actuator depending on the model

Component	Design
Body design	Straight-type, bonnet straight
Handwheel	Bonnet flanged, internal spindle thread, rising
Actuator	flanged, push rod, pneumatic actuator, rising
Obturator	multi-part closing body with gasket
Spindle bushing	Non self-sealing, gland

4.2 Marking

The valves are provided with an individual marking for identification.

Symbol	Explanation
DN.....	Nominal size
PN.....	Rated working pressure (max. permissible operating pressure)
-.....°C +.....°C	Temperature
	Manufacturer's mark "HEROSE"
01/18	Date of manufacture MM/YY
12345	Type
01234567	Serial no.
EN1626	Standard
 0045	CE-mark and number of the notified body
 0045	PI-mark and number of the notified body
e.g. CF8 / 1.4308	Material

4.3 Mode of operation

The gate valves are one-sided sealing valves that shut off the media in the flow direction. The gate valve is closed or opened by turning the handwheel.

Gate valves with an actuator are driven by a compressed air supply, e.g. via an 8.0 mm hose, with a recommended operating pressure of 6.0 bar, max. 10.0 bar. The gate valve is opened by the supply air and closed by the spring. A reverse mode of operation is not possible.

Emergency actuation:

The gate valve is opened by 30.0 mm by turning the 27 AF set screw directly above the actuator in the counter clockwise direction; turning it clockwise closes the gate valve.

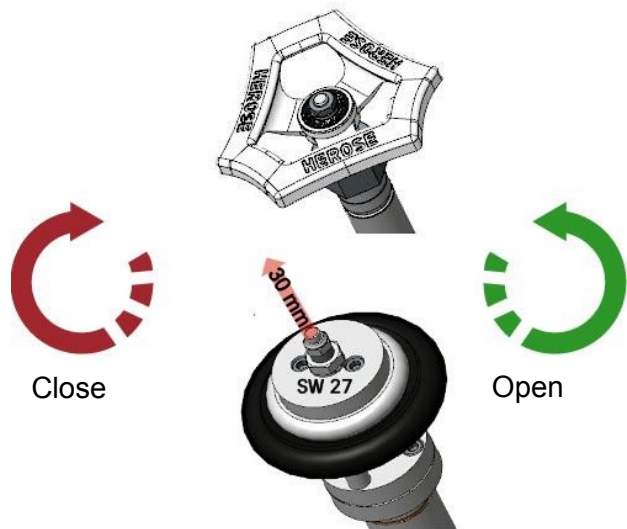

4.4 Operating data

Valve	Rated pressure	Temperature	Operating pressure Actuator	Max. actuator operating pressure
9116 / 9116F	PN 50	-196 °C to +120 °C	6 bar	10 bar
093xx				
094xx				

4.5 Media

Gases, cryogenic liquefied gases and their gas mixtures, such as:

Name
Argon
Chlorotrifluoromethane
Nitrous oxide,
Ethane,
Ethylene,
Helium,
Carbon dioxide,
Carbon monoxide
Liquid krypton, deep-cooled
LNG
LPG,
Air,
Methane,
Neon,
Oxygen,
Nitrogen,
Trifluoromethane,
Hydrogen,
Xenon,

4.6 Scope of delivery

- Valve
- Operating instructions

4.7 Dimensions and weights

► See catalogue page.

4.8 Lifetime

The user is obligated to use Herose products for their intended purpose.

In this case, a technical service life may be assumed in accordance with the underlying product standards (e.g. EN1626 for shut-off valves and EN ISO 4126-1 for safety valves).

The technical service life can be restarted several times through the exchange of wearing parts within the context of the maintenance intervals, and lifetimes of more than 10 years can be achieved.

If products are stored for a period exceeding 3 years, then the plastic components and elastomer sealing elements fitted to the product should be replaced as a precautionary measure before installation and use.

4.9 Materials

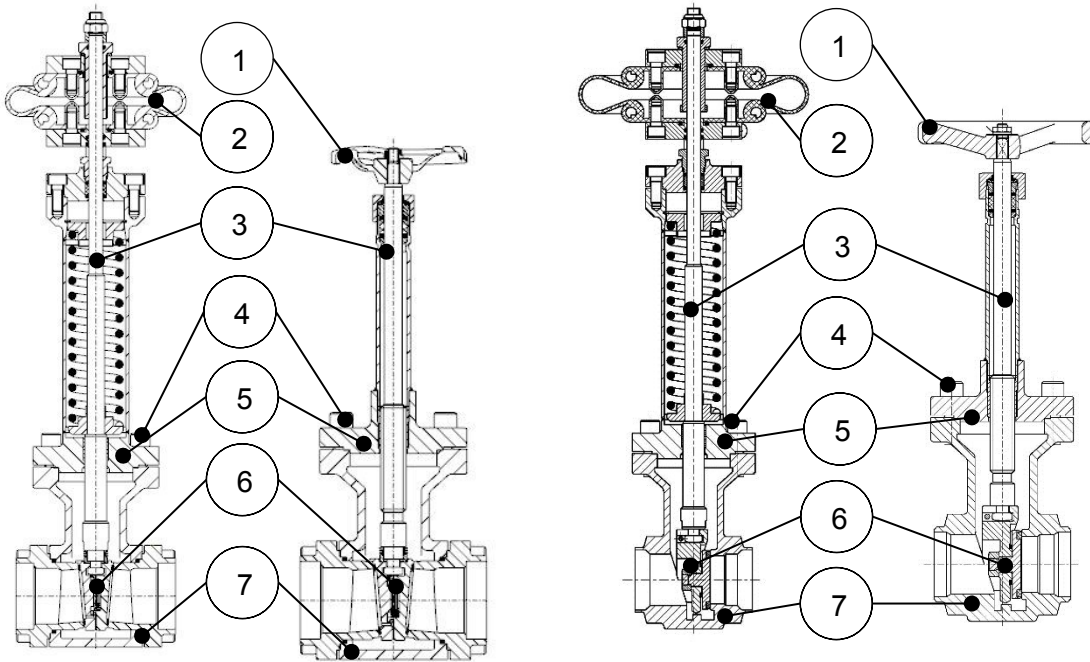

Part no.	Name	Material
1	Handwheel	Aluminium alloy
2	Actuator	Rubber
3	Spindle	1.4301
4	Screws	A2-70
5	Bonnet	1.4308; 1.4541; 1.4301; 1.4306
6	Closing body	1.4571; PTFE/carbon CW614N; 1.4305; Hostafon TF4215, TFM 1600, TFM 1700
7	Body	1.4308

5 Assembly

5.1 Installation position

With regard to the installation position, pay attention to the flow direction arrow. When installing the valve in a horizontal pipeline, a vertical position of the spindle is recommended with the handwheel at the top or an inclination of up to 45° from the vertical.





5.2 Notes regarding the installation

- ▶ Use suitable tools.
 - Allen keys of sizes 6, 8, 10, 14, 19;
 - Open-ended spanners;
 - Torque wrench;
 - Pipe wrench;
 - TIG welding machine;
 - Oxy-fuel welding machine;
- ▶ Clean tools before the installation.
- ▶ Open the packaging only directly before the installation. Free from oil and grease for oxygen (O₂). Valves for oxygen are permanently marked with "O₂".
- ▶ Install the valve if the operating pressure and operating conditions correspond to the marking on the valve.
- ▶ Remove protective caps or covers before assembly.
- ▶ Inspect the valve for dirt and damage. DO NOT install a damaged or dirty valve.
- ▶ Remove any dirt and residues from the pipeline and valve in order to prevent leaks.
- ▶ Avoid damaging the connections.
The sealing surfaces must remain clean and intact.
- ▶ Seal the valve with suitable seals.
No sealant (sealing tape, liquid sealing tape) may enter the valve.
Respect the suitability for use with O₂.
- ▶ Connecting flanges must line up with each other.
- ▶ Tighten the bolts crosswise to the permissible torque
Use all of the flange holes provided for the flange connection.
- ▶ Connecting pipelines must only be connected in a force-free and torque-free manner during operation. Stress-free installation.
- ▶ In order to ensure trouble-free operation, no impermissible static, thermal or dynamic stresses may be transmitted to the valve. Observe reactive forces.
- ▶ Temperature-dependent changes in length in the pipeline system must be compensated with expansion joints.
- ▶ The valve is supported by the pipeline system.
- ▶ The valve must be protected against dirt and damage during construction work.
- ▶ Check the leak-tightness.

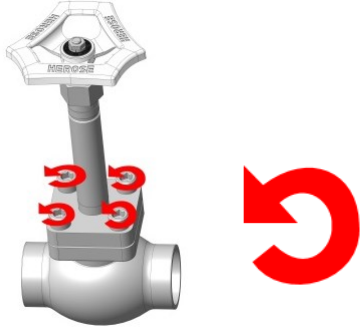
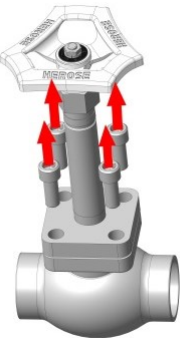

5.3 Welding / soldering



Welding / soldering of the valves and any heat treatment that may be required are the responsibility of the contracting construction company or operating company.

■ Before welding / soldering

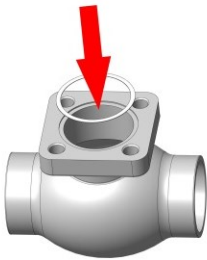
	<ul style="list-style-type: none"> ▶ Loosen the bolts Direction of rotation: counter clockwise
	<ul style="list-style-type: none"> ▶ Remove the bolts
	<ul style="list-style-type: none"> ▶ Remove bonnet and seal
	<ul style="list-style-type: none"> ▶ Dispose of the seal
	<ul style="list-style-type: none"> ▶ Weld / solder in the body

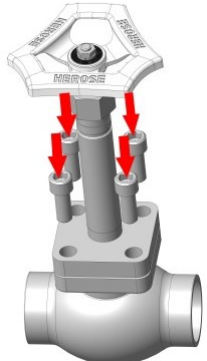
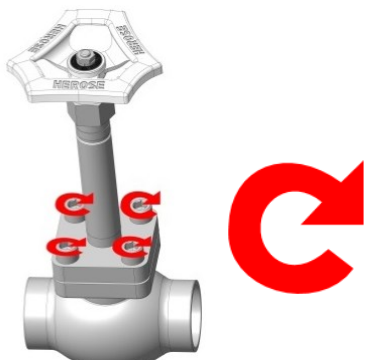
■ After welding / soldering

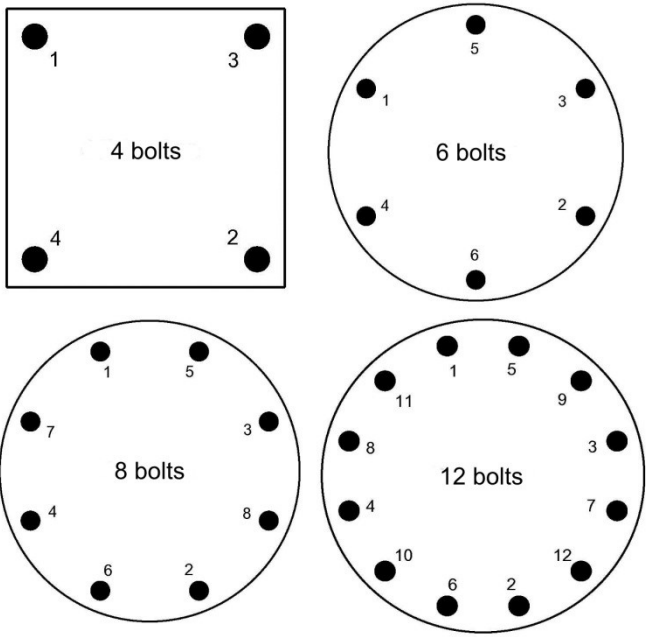
	<p>▶ Insert a new seal</p>
	<p>▶ Mount the bonnet ⚠ Do not damage the seal</p>
	<p>▶ Mount the bolts</p>
	<p>▶ Tighten the bolts to the specified tightening torque in a criss-cross pattern Direction of rotation: clockwise</p>

	<p>► Assembly sequence for the bolts</p>																					
<table border="1" style="margin: auto; border-collapse: collapse;"> <thead> <tr style="background-color: #92d050;"> <th style="padding: 5px;">Nominal size</th> <th style="padding: 5px;">Tightening torque [Nm]</th> <th style="padding: 5px;">Cap bolts</th> </tr> </thead> <tbody> <tr> <td style="padding: 5px;">DN 25</td> <td style="padding: 5px;">50</td> <td style="padding: 5px;">M10</td> </tr> <tr> <td style="padding: 5px;">DN 40</td> <td style="padding: 5px;">70</td> <td style="padding: 5px;">M12</td> </tr> <tr> <td style="padding: 5px;">DN 50</td> <td style="padding: 5px;">70</td> <td style="padding: 5px;">M12</td> </tr> <tr> <td style="padding: 5px;">DN 65</td> <td style="padding: 5px;">90</td> <td style="padding: 5px;">M12</td> </tr> <tr> <td style="padding: 5px;">DN 80</td> <td style="padding: 5px;">110</td> <td style="padding: 5px;">M16</td> </tr> <tr> <td style="padding: 5px;">DN 100</td> <td style="padding: 5px;">130</td> <td style="padding: 5px;">M16</td> </tr> </tbody> </table>	Nominal size	Tightening torque [Nm]	Cap bolts	DN 25	50	M10	DN 40	70	M12	DN 50	70	M12	DN 65	90	M12	DN 80	110	M16	DN 100	130	M16	<p>► Bonnet / body tightening torques</p>
Nominal size	Tightening torque [Nm]	Cap bolts																				
DN 25	50	M10																				
DN 40	70	M12																				
DN 50	70	M12																				
DN 65	90	M12																				
DN 80	110	M16																				
DN 100	130	M16																				
	<p>► Check the leak-tightness</p>																					

6 Operation

- Before start-up, compare all the details relating to material, pressure, temperature and installation position with the layout plan for the pipeline system.
- Remove any dirt and residues from the pipelines and valves in order to prevent leaks.
- Check the following points prior to start-up:
 - All assembly and installation work are completed.
 - The operating position of the valve is correct.
 - The safety guards are in place.

7 Maintenance and service

7.1 Safety during cleaning

- ▶ Take note of the specifications in the safety data sheet and the general occupational health and safety rules if degreasers are used for process-related reasons for the cleaning of bearing parts, fittings and other precision parts.

7.2 Maintenance

The maintenance intervals must be defined by the user according to the operating conditions.

The recommendations for the functional checking of the valves are to be taken from section 7.2.1 "Inspection and maintenance intervals" in these operating instructions.

7.2.1 Inspection and maintenance intervals

Inspection	During start-up	annually	2 years	5 years	10 years
▶ Correspondence to <input type="checkbox"/> design drawing, <input type="checkbox"/> specifications, <input type="checkbox"/> type approval, <input type="checkbox"/> marking,	X	-	-	-	-
▶ Suitability (medium, size, temperature, pressure, setting)	X	-	-	-	-
▶ Visual inspection <input type="checkbox"/> of the valve for damage <input type="checkbox"/> of the marking for legibility	X	X	X	X	X
▶ Correspondence of the technical data for the valve to the documentation	X	X	X	X	X
▶ Leak-tightness <input type="checkbox"/> between bonnet and body <input type="checkbox"/> of the valve seat <input type="checkbox"/> at the gland packing	X	X	X	X	X
▶ Opening and closing of the valve	X	X	X	X	X
▶ Static pressure test with clean water or another suitable liquid	-	-	-	-	X
▶ Visual inspection of the plant components for cracks, inadmissible changes in shape or leaks	-	-	-	-	X

7.3 Fault table

Fault	Cause	Remedial action
<ul style="list-style-type: none"> ■ Leak at the spindle 	<ul style="list-style-type: none"> Gland nut loose Gland packing defective Fit on the spindle damaged 	<ul style="list-style-type: none"> ▶ Retighten the gland nut ▶ Replace the gland packing ▶ Replace the spindle
<ul style="list-style-type: none"> ■ Leak between bonnet and body 	<ul style="list-style-type: none"> Bonnet loose Seal damaged 	<ul style="list-style-type: none"> ▶ Tighten the bolts to the specified tightening torque ▶ Replace seal
<ul style="list-style-type: none"> ■ Leak in the seat 	<ul style="list-style-type: none"> Foreign body between cone and seat Seat damaged Cone seal damaged 	<ul style="list-style-type: none"> ▶ Remove foreign body / flush the system ▶ Replace the body ▶ Replace the cone
<ul style="list-style-type: none"> ■ Body leaking 	<ul style="list-style-type: none"> Discontinuity/gas cavity open 	<ul style="list-style-type: none"> ▶ Replace the body
<ul style="list-style-type: none"> ■ Valve does not open / close 	<ul style="list-style-type: none"> Gland nut overtightened Thread seized Actuator not working 	<ul style="list-style-type: none"> ▶ Loosen the gland nut Tightness must still be ensured ▶ Replace bonnet ▶ Check supply of energy to the actuator

7.4 Spare parts

We require the following details for your spare part orders:

- Article no. of the spare part package,
- desired delivery quantity,
- dispatch and delivery address,
- desired method of dispatch.

7.5 Returns / complaints

Use the Service form in case of returns/complaints.



Contact in case of service:
 Herose.com › Start › Service › Product service › Complaints
 E-mail: service@herose.com
 Fax: +49 4531 509 – 9285

8 Disassembly and disposal

8.1 Notes regarding the disassembly

- ▶ Take note of all national and local safety requirements.
- ▶ The pipeline system must be depressurised.
- ▶ The medium and valve must be at ambient temperature.
- ▶ Aerate / flush the pipeline in the case of corrosive and aggressive media.

8.2 Disposal

1. Dismount the valves.
 - ▶ Collect greases and lubricating fluids during dismantling.
2. Separate the materials:
 - Metal
 - Plastic
 - Electronic scrap
 - Greases and lubricating fluids
3. Carry out a sorted disposal of the materials.

